

mt-propeller

ATA 61-20-48
(E-1048)

Operation and Installation Manual

**Hydraulically
Constant Speed Governor**

P-8()-()

Issue 2: May 26, 2004

LBA approved

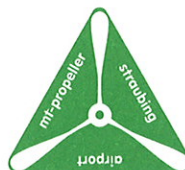

EASA DE.21G.0008
EASA.21J.020

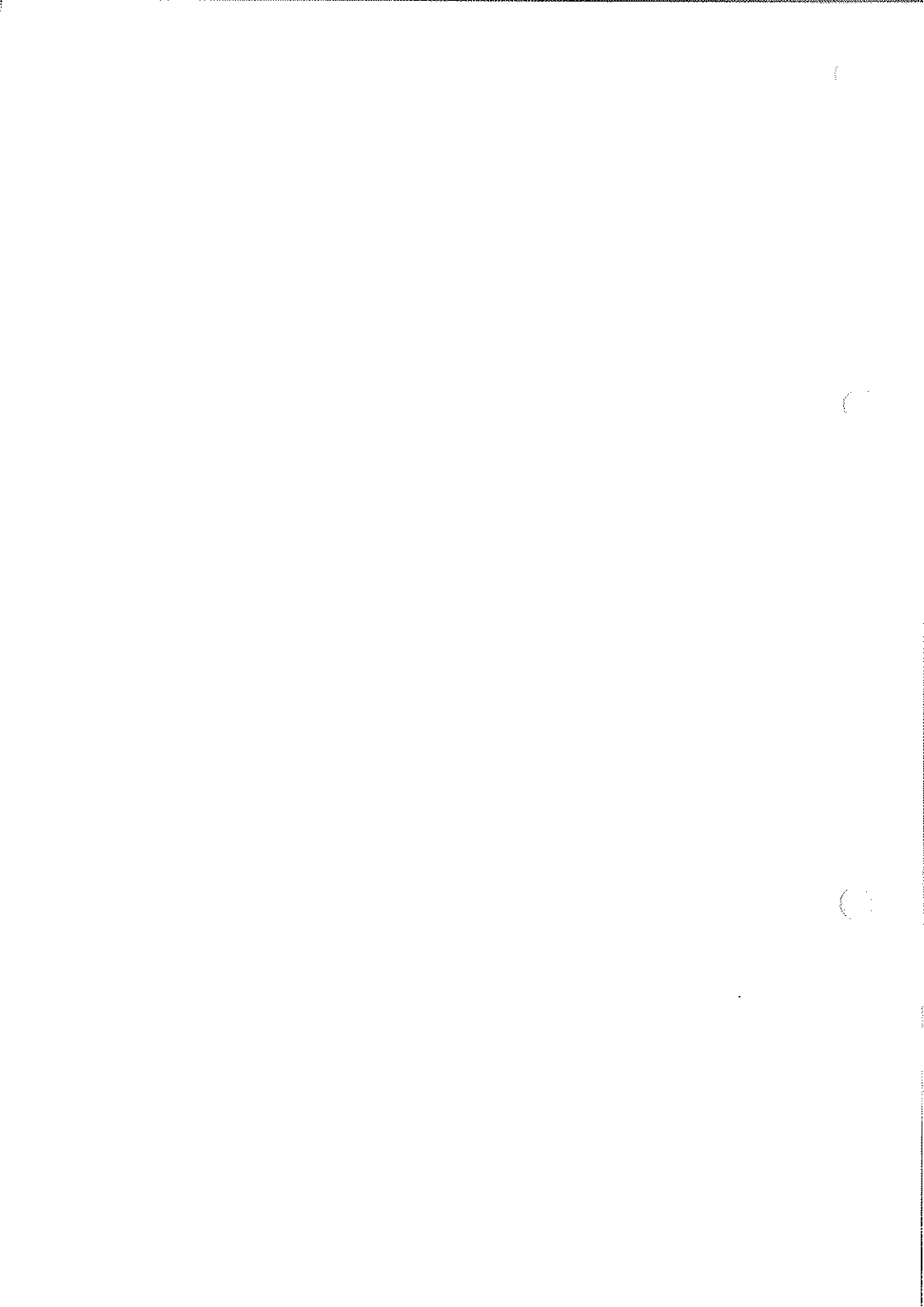



Warning

People who fly should recognize that various types of risks are involved; and they should take all precautions to minimize them, since they can not be eliminated entirely. The governor is a vital component of the aircraft. A mechanical failure could cause a forced landing.

Governors are subject to constant vibration stresses from the engine.

Before a governor is certified as being safe to operate on an airplane engine, an adequate margin of safety must be demonstrated. Even though every precaution is taken in the design and manufacture of a governor, history has revealed rare instances of failures, particularly of the fatigue type.

It is essential that the governor be properly maintained according to the recommended service procedures and a close watch be exercised to detect impending problems before they become serious. Unusual operation characteristics should be investigated and repaired as it could be a warning that something serious is wrong.

As a fellow pilot, I urge you to read this Manual thoroughly. It contains a wealth of information about your new governor.

The governor is among the most reliable components of your airplane. It therefore deserves the care and maintenance called for in this Manual. Please give it your attention, especially the section dealing with Inspections and Checks.

Thank you for choosing a MT-Propeller governor, manufactured by AVIA Propeller. Properly maintained it will give you many years of reliable service.

Gerd R. Mühlbauer
President
MT-Propeller Entwicklung GmbH



Table of contents	Page
Table of Contents (Overview)	1
List of inserted revisions	2
List of effective pages	3
1. General	4
2. Model Designation	5
3. Performance Data	5
4. Design and Operation Information	6
5. Installation and Operation Instruction	9
6. Inspections	15
7. Trouble Shooting	16
8. Shipping and Storage	17
9. Governor installation record	18



List of Inserted Revisions

No.	Date of Issue	Pages	Remark
1	2004-05-02	all	Initial Issue
2	2004-05-26	2, 3, 9, 10	



List of Effective Pages

Page	Date of Issue
0-1	2004-05-02
1	2004-05-02
2	2004-05-26
3	2004-05-26
4	2004-05-02
5	2004-05-02
6	2004-05-02
7	2004-05-02
8	2004-05-02
9	2004-05-26
10	2004-05-26
11	2004-05-02
12	2004-05-02
13	2004-05-02
14	2004-05-02
15	2004-05-02
16	2004-05-02
17	2004-05-02
18	2004-05-02
19	2004-05-02



2.0 MODEL DESIGNATION

P - 8 6 0 17

1 2 3 4 5

1 P = Propeller Governor

2 8 = Manufactured for MT-Propeller by AVIA Propeller

3 5 = Pressure to increase pitch. CCW facing engine mounting pad

6 = Pressure to increase pitch. CW facing engine mounting pad

7 = Pressure to decrease pitch. CCW facing engine mounting pad

8 = Pressure to decrease pitch. CW facing engine mounting pad

4 = Special arrangements

0 = Standard

1 = Feathering

2 = Higher Pump Capacity

3 = Electronic Control

4 = Accumulator Connection

5 = Unfeathering

6 = Synchronphasing

5 = Application Number, Settings of Control Lever and Relief Valve Pressure etc.

S/No. 03 G 003

a b c

a = Year of Manufacture

b = Governor

c = Consecutive Number

3.0 PERFORMANCE DATA

Range of acceptable operation temperature from -16°C (+3.2°F) to +150°C (+302°F)

The governor uses engine oil with a pressure at the inlet channel between 15 and 125 psi.

The break away torque with engine oil SAE No. 40 at 4.5°C (+40°F) is 40 Nm (30 ft lbs)

The torque required at 220 psi and 2700 rpm is 1 Nm (8 inch lbs)

3.1 Dimensions

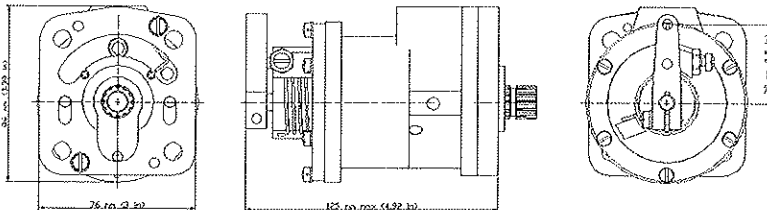

Fig. 1

Weight =1 kg (2,05 lbs) in basic configuration.



4.0 DESIGN AND OPERATION INFORMATION

The **MT-Propeller** aircraft governors P-8()-() are base mounted centrifugal governors for use with hydraulic constant speed propellers on single or twin engine aircraft.

They regulate aircraft engine speed by continually varying the pitch of the propeller to match propeller torque (and, hence, engine load) to engine developed torque as changes occur in flight conditions. The governors are single-acting, using oil pressure either to increase or decrease pitch. Pitch change in the opposite direction is accomplished by the force of the propeller blade twisting moment and servo spring, or propeller counterweights.

The pilot valve plunger used is balanced with the flyweights to eliminate axial movement of the plunger due to engine vibration parallel to the axis of the plunger. This feature increases governing stability on engines with lateral vibration characteristics.

The principal parts of each governor are a gear-type oil pump with pressure relief valve, flyweights pivoted on a rotating flyweight head, a spring-loaded pilot valve positioned by the flyweights, an external control lever that varies the spring load on the pilot valve.

The body, cover and base are made of aluminum. The body contains the necessary passage to channel oil to the propeller pitch changing mechanism, and the base is designed to fit the standard AND20010 engine pad.

The sensing element of the governor is a set of pivoted flyweights mounted on a rotating flyweight head and linked mechanically to the engine gears, through a hollow drive gear shaft.

The flyweights, actuated by the centrifugal force developed by the speed of the rotation, position a pilot valve so as to cover or uncover ports in the drive gear shaft and control the flow of oil to and from the pitch changing mechanism of the propeller. The centrifugal force exerted by the flyweights is opposed by the force of an adjustable speeder spring. The load exerted by the speeder spring determines the engine rpm required to develop sufficient centrifugal force in the flyweights to center the pilot valve. Oil to operate the propeller's pitch changing mechanism is supplied by a gear-type oil pump at a pressure value limited by a relief valve.

ON SPEED:

In this condition the forces action on the engine-governor-propeller combination are in a state of balance. The speed adjusting control lever has been set by the pilot to obtain the desired engine rpm. The propeller blades are at the correct pitch to absorb the power developed by the engine. The centrifugal force of the rotating flyweights exactly balances the force of the speeder spring. The pilot valve is located in the drive-gear shaft, so that the control ports between the oil pump and the propeller pitch changing servo are covered. Pressure oil from the gear pump is circulated through open governor relief valve back to the inlet side of the pump.



OVERSPEED:

This condition occurs when airspeed or horsepower is increased and engine rpm increases above the onspeed value - set by the speed adjusting control lever. The rotating flyweights pivot outward as their increase centrifugal force overcomes force exerted by the speeder spring.

Counterweighted Propeller using Pressure to Decrease Pitch. (see Fig. 2)

The flyweight toes raise the pilot valve plunger, uncovering ports in the driver gear shaft that permit pressure oil to flow from the propeller pitch changing mechanism. This allows propeller counterweights to take the propeller blades toward a higher pitch. The load on the engine is increased and engine speed is reduced.

Propeller using Pressure to Increase Pitch. (see Fig. 3)

The flyweight toes raise the pilot valve plunger, uncovering ports in the drive gear shaft that permit pressure oil to flow to the propeller pitch change mechanism. This moves the propeller blades to a higher pitch and load on the engine is increased and engine speed is reduced.

This, in turn, reduces centrifugal force exerted by the flyweights in opposition to the force of the speeder spring. The flyweights return to an onspeed position and the pilot valve plunger covers ports in the driver gear shaft, blocking flow of pressure oil to or from the pitch changing mechanism of the propeller – return to onspeed condition.

UNDERSPEED:

An underspeed condition occurs when the airspeed or horsepower is decreased and engine rpm falls below the rate established by the setting of the speed adjusting control lever. The decrease in the centrifugal force of the rotating flyweights causes them to pivot inward under the force exerted by the speeder spring.

Counterweighted Propeller using Pressure to Decrease Pitch. (see Fig. 2)

The pilot valve plunger is forced down uncovering the ports in the drive gear shaft that allow pressure oil to flow to the pitch changing mechanism of the propeller. This overcomes the force of the propeller counterweights and decreases the pitch of propeller blade.

Propeller using Pressure to Increase Pitch. (see Fig. 3)

The pilot valve plunger is forced downward, uncovering the ports in the driver gear shaft, thus allowing oil to flow from the pitch changing mechanism of the propeller to sump. This permits the centrifugal twisting moment of the blades to decrease propeller pitch.

This reduces the load on the engine, thereby increasing engine speed and the centrifugal force developed by the rotating flyweights. The flyweight toes lift the pilot valve plunger to cover the control ports. At this point the forces acting on the engine-governor-propeller combination are again balanced and the engine is back to the onspeed setting.

NOTE

LOSS OF OIL FROM THE PROPELLER PITCH CHANGING MECHANISM DUE TO ENGINE TRANSFER RING LEAKAGE WILL RESULT IN CHANGED SPEED SETTINGS.

Pressure to decrease pitch Type Pilot Valve

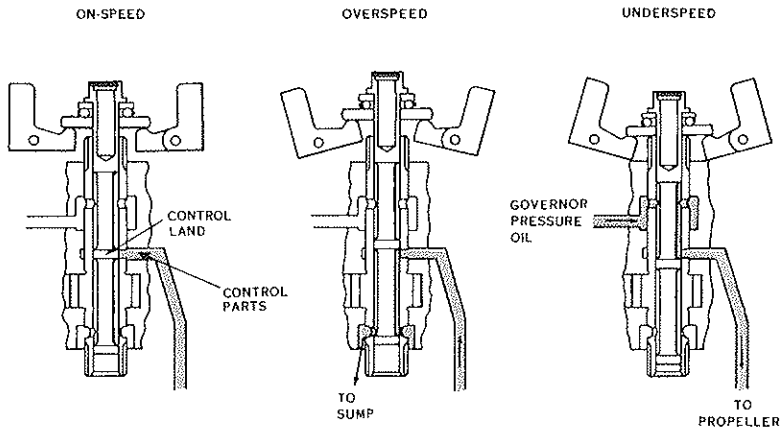

Fig. 2

Pressure to increase pitch Type Pilot Valve

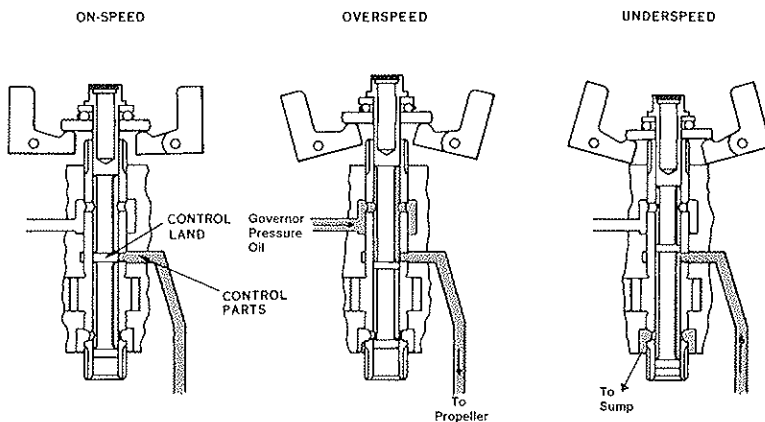

Fig. 3



5.0 INSTALLATION AND OPERATION INSTRUCTION

- 5.1
- a) If applicable: Remove old governor per aircraft service instructions.
 - b) If applicable: Remove push-pull linkage bracket from original governor.
 - c) If applicable: Remove required top cover screws from new governor and install push pull linkage bracket to top of governor and torque screws 18-24 in. lbs. 2-3 Nm

Prepare new mounting gasket, P/N B-20024. Coat gasket with engine oil or equivalent before installation.
 - d) Check that mounting studs project a minimum of 31,75 mm (1.250 in) from face of engine pad.
 - e) Clean engine pad, studs and mounting hardware before installing new mounting gasket. Insure governor drive spline mate correctly with engine accessory drive spline.
 - f) Attach mounting hardware and torque the (4) mounting nuts to 11-15 Nm (100-140 in lbs).
 - g) Reconnect push-pull control to outermost hole on governor control lever and adjust linkage per aircraft service information.
 - h) In case an accumulator is connected make sure that the tube to the accumulator is fixed correctly.
NOTE: IN CASE THE ACCUMULATOR IS NOT FIXED CORRECTLY, THE TUBE MAY VIBRATE CAUSING IT TO COME LOOSE AND FINALLY BREAK, WHICH WILL RESULT IN EXCESSIVE OIL LOSS.
 - i) Flight check aircraft for proper RPM setting. Record amount of change required at different flight conditions. Tests should be done in smooth air.
 - j) If adjustment is required, remove cowling, cut lockwire, loosen jam nut and turn max RPM screw clockwise or counterclockwise
- NOTE:** One full turn clockwise will reduce RPM by approximately 25 RPM
One full turn counterclockwise will increase RPM by approximately 25 RPM.
- k) Also check for oil leaks - none permitted.

5.2 AIRCRAFT FLIGHT CHECK

Before Static Run-up check feathering on feathering governors in accordance with aircraft service instructions or pilot manual.



5.3 PERFORM STATIC RUN-UP:

ATTENTION: PERFORM THE STATIC RUN UP ON A CLEAN AREA , TO NOT DAMAGE THE PROPELLER BLADES DUE TO STONES ETC.

Lock aircraft brakes. Place cockpit propeller RPM lever in MAX RPM position. Advance throttle slowly to maximum permitted engine manifold pressure limits. Record propeller RPM. If local wind conditions are over 2.5 m/s, 5 knots repeat check with aircraft pointed to opposite direction and average two numbers. As a general rule, propeller should be 25-100 RPM below the red line limit during check.

PULL BACK THE PROPELLER LEVER 3 TO 5 TIMES TO SPILL THE SYSTEM AND REMOVE THE AIR IN THE SYSTEM.

5.4 PERFORM FLIGHT TEST

During takeoff acceleration, record maximum propeller RPM. When sufficient altitude is reached, level out aircraft, leaving propeller control in MAX RPM position. Maintain this setting for 3 to 5 minutes while monitoring propeller RPM. Following this check, two conditions may exist which require adjustment:

- 5.4.a If the propeller RPM is exceeding the redline limit, reduce it to the redline using propeller control. Leaving propeller at this redline RPM setting, land aircraft and shutdown. Remove cowling and note position of control arm and governor. Adjust governor high RPM screw clockwise so it just touches stop on governor control arm; this will ensure that the correct arm position for governor redline RPM setting cannot be exceeded.
- 5.4.b If the propeller is below red line limit with max RPM setting on the propeller cockpit control, note RPM and land. Remove engine cowling and adjust the governor high RPM screw counterclockwise to increase of approximately 25 RPM. Perform another flight to confirm the adjustment was sufficient.

Remove engine cowling and check for the oil leaks. Oil leaks aren't permitted.

Make a record in governor installation record.

5.5 GENERAL

Static Run Up

There has been some confusion in the field concerning propeller low blade angle setting, the governor setting and how it relates to static run-up and take-off RPM.

As a general rule, engine redline RPM cannot be reached during a full power static run-up. Contrary to popular belief, the governor is not controlling the propeller at this time, the propeller is against its low pitch stop. Attempting to increase propeller static run-up RPM by adjusting the governor high RPM screw will have no effect and will probably result in a propeller overspeed during the take-off roll.

For further information see applicable Propeller Manual.



5.6 GOVERNOR HEAD / LEVER AND RPM ADJUSTMENT

5.6.a Control head / lever adjustment (see Fig. No. 4)

It is possible to position the governor head / control lever to any position, see fig. 4.

Remove safety wires from six screws, position 1, fig. 4.

Loosen these six screws such a way, that it is possible to turn with control head.

Turn the control head to desired position.

Tighten these six screws (torque 22 in. Lbs), secure with lock-wire AMS5687 or equivalent, see fig. 4.

ATTENTION: CHECK THAT THE GASKET BETWEEN HEAD AND GOVERNOR BODY IS NOT DAMAGED DURING ADJUSTMENT. OTHERWISE OIL LEAK WILL OCCUR WHICH IS NOT ACCEPTABLE.

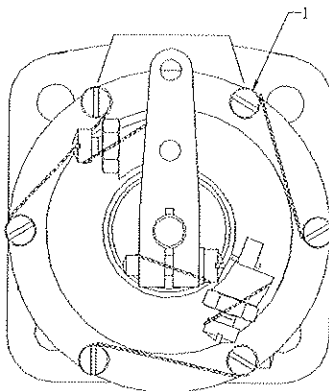

Fig No. 4



5.6.b Adjusting maximal (minimal) propeller RPM (see Fig. 5 and 6)

Note:

It is possible to set maximum rpm with the described procedure only in a limited range. This is a normal maintenance procedure and fully authorized.

Remove lock wire from the stop screw, fig. 6. pos. 1 (3) and loosen the lock nut 2 (4) of the screw 1 (3).

Set maximal (minimal) propeller's RPM by turning the stop screw. One full turn clockwise will reduce (increase) RPM by approximately 25 RPM. One full turn counterclockwise will increase (reduce) RPM by approximately 25 RPM.

If the requested RPM can not be reached, the control lever must be repositioned. It is recommended to do this at authorized service station.

Lock the stop screw at maximal RPM stop and torque the nut with 2.5 Nm (22 in. Lbs).

ATTENTION: AFTER ADJUSTMENT THE STOP SCREW MUST OVERLAP THE STOP SCREW SUPPORT AT LEAST 2MM (0,08 INCHES)

Check position of control shaft with control lever at the max. RPM stop (see Fig. 5)
Assure that the splines are not beyond the governor housing, otherwise the o-ring could be damaged. This will result in a oil leakage, which is not acceptable.

Lock screw at maximal (minimal) RPM stop with safety wire (see Fig. 6).

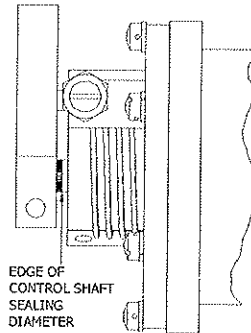

Fig No.5

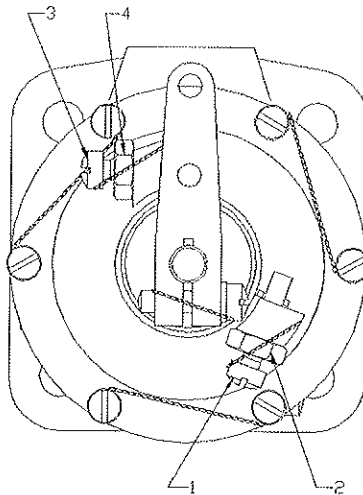

Fig. 6



5.6.c Adjusting relief valve pressure (see Fig. 7)

Remove the governor in accordance with section 5.6.e.

Release the lock spring at the governor base.

Set required relief valve pressure by turning the adjusting screw. One full turn clockwise will increase the relief valve pressure by approximately 36 psi. One full turn Counterclockwise will reduce the relief valve pressure by approximately 36 psi.

Lock the nut by the lock spring.

Install the governor in accordance with section 5.0.

ATTENTION: THE RELIEF VALVE PRESSURE IS NORMALLY SET TO 310 PSI \pm 10 PSI. A HIGHER INCREASE OF THE PRESSURE CAN RESULT IN A DAMAGE OF THE PITCH CHANGE MECHANISM OF THE PROPELLER.

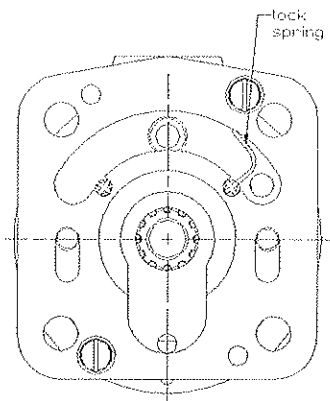

Fig. 7

5.6.d Adjusting of feathering

Required Tools: Appropriate lift rod adjusting wrench.

If feathering RPM is too high:

- Turn lift rod CW $\frac{1}{4}$ RPM, this results in a RPM decrease of app. 50 RPM.

If feathering RPM is too low:

- Turn lift rod CCW $\frac{1}{4}$ RPM, this results in a RPM increase of app. 50 RPM.

ATTENTION: MARK ORIGINAL POSITION OF THE LIFT ROD PRIOR TO ADJUSTMENT. AFTER ADJUSTMENT SECURE LIFT ROD BY THE PRIOR LOOSENED STOP NUT.



5.6.e Governor removal

Remove push-pull linkage in accordance with aircraft service instructions.

Remove mounting nuts and washers.

Pat on the governor to release it and then remove governor from engine pad.

Governor drive and engine pad must be without impurities. (metal chips etc.)

If it is necessary clean governor drive and engine pad by appropriate means.

Apply the gasket and transport cover to governor base.

Record the removal in governor installation record.

Perform preservation in accordance with section 8.0 to prepare for long-term storage.

Storage in accordance with section 8.0

6.0 INSPECTIONS

Check for oil leakage.

Check oil leakage immediately after engine stop.

Check oil leakage at governor's surface and at mounting pad.

If oil leakage is detected check stop nuts at the governor housing and the mounting nuts. Torque if necessary. If oil leakage is detected repeatedly contact service center or governor's manufacturer.

WARNING: NO OIL LEAKAGE IS PERMITTED



7.0 TROUBLE SHOOTING

Propeller Surging or "Wandering" - Possible Causes:

7.1 EXCESSIVE TRANSFER BEARING LEAKAGE

Engines with excessive transfer bearing leakage can experience surging since the governor may not be able to get enough pressure to the propeller. This causes a delay in propeller responsiveness and by the time the propeller responds to earlier governor inputs, they have changed, resulting in propeller "wandering".

Solution: Perform a transfer bearing leakage test per engine manufacturer's instructions. If test indicates a high rate of leakage (even though it may still be on the high side of "acceptable" tolerance), this maybe your cause. Install the suspect governor on a known "good" aircraft, if problem disappears, engine work may be indicated.

7.2 MALFUNCTIONING MAGNETOS

7.3 DIRTY ENGINE OIL

Contaminants in dirty engine oil can cause blockage of close tolerance passages in governor, leading to erratic operation.

Solution: Timely engine oil changes should eliminate this problem.

7.4 EXCESSIVE "PLAY" IN AIRCRAFT PROPELLER CONTROL LINKAGE

Excessive "play" in the linkage between the governor and the cockpit control often leads to erratic operation. Specifically, if the propeller RPM is suddenly changing and holding a new setting on its own, this could indicate loose linkage.

Solution: Trace linkage and locate unsecured sections and tighten-up as needed. Please note that although linkage may appear to allow full governor control while the engine is off, it may not in the air. Engine vibration and "stretch" of the mount during operation can often aggravate the condition. Therefore, it is important the entire length of linkage be properly secured, even if the ends alone are tight.

7.5 EXCESSIVE PROPELLER FRICTION

(NOTE: This is rarely the cause of RPM malfunction.)

Propeller may be overly-resistant to pitch movement. This can be caused by either excessively tight shimming of the propeller blades, or internal corrosion or part failure, causing binding.

Solution: Check amount of blade "play" as defined below:

A total lack of blade "shake" may indicate excessively tight blade shims. If this is suspected, have the propeller checked by a qualified FAA-approved propeller repairman. Note that this check and any needed correction can usually be performed with the propeller installed on the aircraft.



8.0 SHIPPING AND STORAGE

Conservation

Inner conservation is automatically done by engine oil. Attach cover cap.

After installing the governor the conservation is done together with engine in accordance with the instruction of the engine manufacturer.

Outside conservation isn't required.

Pack the governor in two layers of wax-cloth and put it in a plastic bag. The plastic bag should be vacuumed and after that welded.

Make a note in the governor's installation record.

Deconservation isn't needed.

Storage

Governors have to be packed in carton box with accessory documentation.

Store governors in temperature from +10°C (+50°F) to +30°C (+86 °F) and relative humidity from 40 % to 80 %. Keep stock room free of gases with deleterious effect.



Warranty Registration Card

- 1) To be eligible for warranty, this registration card must be returned completed and signed by the end user to the authorized MT-Propeller distributor of the area in which the governor is firstly operated or to MT-Propeller itself within 30 days after date from starting operation.
- 2) No other warranties and/or guarantees than defined in the actual warranty conditions are made.
- 3) Governor Type:

P	-					-				
---	---	--	--	--	--	---	--	--	--	--

S/N:

--	--	--	--	--	--	--	--

Date of purchase (day/month/year):_/_/

Date of De-conservation (day/month/year):_/_/

Owner's name:

Company:

Address:.....

City/State/Postal code

Country:

Telephone:..... Telefax:.....

E-mail:

Sold by:

I have read and understood the Operator's Manual in its entirety and will observe the instructions therein.

Date:..... Signature:.....



Kompetenz in Propellern

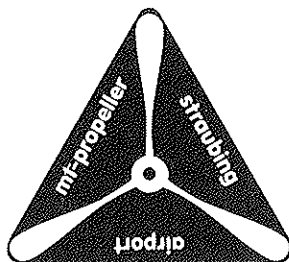

mt-propeller

Flugplatz Straubing-Wallmühle

D-94348 Atting

Tel. (0 94 29) 94 09 - 0 · Fax (0 94 29) 84 32

Internet: www.mt-propeller.com

online service: Service Bulletins, technical data, contacts

EASA DE.145.0115

FAA-Nr. MFNY 838 K

EASA DE.21G.0008

EB: EASA.21J.020