

SECTION 1
GENERAL

		Page
1.1	INTRODUCTION	1-2
1.2	AIRCRAFT CERTIFICATION	1-2
1.3	WARNING, CAUTIONS AND NOTES	1-3
1.4	AIRCRAFT PRINCIPAL DIMENSIONS	1-4
1.4.1	Dimensions Overall	
1.4.2	Wings	
1.4.3	Horizontal Stabilizer & Elevator	
1.4.4	Fuselage and Vertical Stabilizer & Rudder	
1.4.5	Landing Gear	
1.5	AT01 THREE VIEW	1-5
1.6	ENGINE	1-6
1.7	PROPELLER	1-6
1.8	FUEL	1-6
1.9	ENGINE OIL AND ENGINE COOLANT	
1.9.1	Engine Oil	1-7
1.9.2	Engine Coolant	1-8
1.10	WEIGHTS	1-8
1.11	TERMINOLOGY AND ABBREVIATIONS	1-9
1.12	CONVERSION FACTORS	1-11
1.12.1	(RESERVED)	1-12

<i>Document No.:</i>	<i>Issue:</i>	<i>Revised Issue:</i>	<i>Date:</i>	<i>Page:</i>
FM-AT01-1010-100E	A.08	A.01	30.6.05	1-1

1.1 INTRODUCTION

This Pilot's Operating Handbook contains all information that the pilot and instructor need for safe aircraft operation and to get the most utility from the AQUILA AT01.

It includes all data that must be available in accordance with JAR-VLA and additional information provided by the manufacturer for maximum utilization as an operating guide for the pilot.

The handbook is comprised of eight sections, which cover operational aspects of a standard-equipped aircraft. Optional equipment, which was installed on request of the customer (COM, NAV, GPS, and other) is considered in Section 9 "Supplements" of this handbook.

A list of equipment, which may be installed in the aircraft, is provided in Section 6, paragraph 6.5.

1.2 Type Certification

The aircraft model AQUILA AT01 is certificated in accordance with the *Joint Airworthiness Requirements (JAR-VLA) Very Light Aeroplanes* (the revision VLA 192/1 included) by the Luftfahrt-Bundesamt.

The Type Certificate under the Aircraft Data Sheet No. 1106 was issued 21/9/2001.

The aircraft is certificated in the NORMAL Category.

Noise Certificate according to: Noise Requirements for Aircraft (LSL) Chapter X

Additional Noise Requirements: Airfield Noise Requirements, Issue 5.1.1999

Kind of Operation:: VFR, day

Document No.:	Issue:	Revised Issue:	Date:	Page:
FM-AT01-1010-100E	A.08	A.01	30.6.05	1-2

1.3 WARNING, CAUTIONS AND NOTES

Throughout the text, warnings, cautions, and notes pertaining to aircraft handling and operation are utilized. They are defined as follows:

WARNING

Procedures, practices, etc., which may result in personal injury or loss of life if not carefully followed.

CAUTION

Procedures, practices, etc., which if not strictly observed may result in damage to or destruction of equipment.

NOTE

Calls attention to additional procedures or information pertaining to the text.

<i>Document No.:</i>	<i>Issue:</i>	<i>Revised Issue:</i>	<i>Date:</i>	<i>Page:</i>
FM-AT01-1010-100E	A.08	A.01	30.6.05	1-3

1.4 AIRCRAFT PRINCIPAL DIMENSIONS

1.4.1 Aircraft Overall

Wing Span:	10,3	(m)
Length:	7,35	(m)
Height:	2,4	(m)

1.4.2 Wings

Profile:	HQ-XX mod.	
Area:	10,5	(m ²)
Aspect Ratio:	10,1	
Mean Aerodyn.		
Chord (MAC):	1,07	(m)

1.4.3 Horizontal Stabilizer / Elevator

Area:	2,0	(m ²)
Span:	3,0	(m)

1.4.4 Fuselage and Vertical Stabilizer / Rudder

Max. Width	1,20	(m)
Length	7,35	(m)

1.4.5 Landing Gear

Wheel Track:	1,938	(m)
Wheel Base:	1,685	(m)
Tire Sizes		
Nose Gear:	5.00-5	Cleveland
Main Gear:	5.00-5	Cleveland
Tire Pressure		
Nose Gear:	2,0	(bar)
Main Gear:	2,5	(bar)

<i>Document No.:</i>	<i>Issue:</i>	<i>Revised Issue:</i>	<i>Date:</i>	<i>Page:</i>
FM-AT01-1010-100E	A.08	A.01	30.6.05	1-4

1.5 AT01 Three View

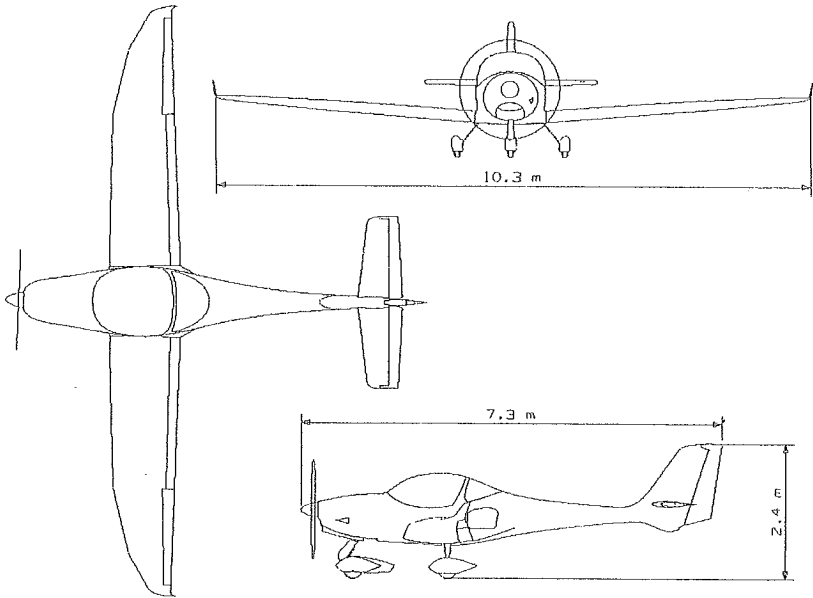

<i>Document No.:</i>	<i>Issue:</i>	<i>Revised Issue:</i>	<i>Date:</i>	<i>Page:</i>
FM-AT01-1010-100E	A.08	A.01	30.6.05	1-5

1.6 ENGINE

Four stroke, four cylinder horizontally opposed, ROTAX® 912 S3 engine with ram air cooled cylinders and liquid cooled cylinder heads.
Prop drive via reduction gear with overload clutch and hydraulic constant speed propeller governor.

Reduction Ratio:	2,43 : 1	
Displacement:	1352	(cm ³)
Take-Off Performance:	69,0	(KW)
at:	2263	(U/min)

1.7 PROPELLER

Two blade, constant speed propeller made by Fa. mt-Propeller Entwicklung GmbH.

Typ:	MTV-21-A/175-05
Hydraulically Controlled Variable	
Pitch (Constant Speed) Propeller	
Max. Propeller Diameter:	175 (cm)

1.8 FUEL

The following fuels can be used (min. RON 95):

EN228 Premium
EN228 Premium plus
AVGAS 100LL

	<u>Left Fuel Tank</u>	<u>Right Fuel Tank</u>
Fuel Capacity (total):	60	60 (Liters)
Usable Fuel (total) :	54,8	54,8 (Liters)
Unusable Fuel:	5,2	5,2 (Liters)

Due to the higher lead content in AVGAS, the wear of valve seats, the deposit in the combustion chamber and lead sediments in the lubrication system will increase.
Therefore, use AVGAS only if you encounter problems with vapour lock or if the other fuel types are not available.

(see also Operators Manual for ROTAX® Engine Type 912 Series, latest revision)

Document No.:	Issue:	Revised Issue:	Date:	Page:
FM-AT01-1010-100E	A.08	A.01	30.6.05	1-6

1.9 ENGINE OIL AND ENGINE COOLANT

1.9.1 Engine Oil

Use only oil with API classification "SF" or "SG".

Heavy duty 4-stroke motor cycle oils meet normally all the requirements.

Refer to Operator's Manual for all versions of 912 series engines section 10.2.3., and to ROTAX® Service Information SI-18-1997 latest revision, for more information.

The following chart shows the recommended oil viscosity in dependence on climatic conditions. Use of multi-grade oils is recommended.

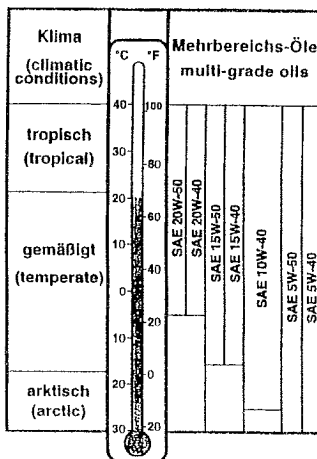

Figure 1-2

CAUTION

Do not use aviation grade oil !

When operating the engine with AVGAS do not use full synthetic oil types !

When operating the engine with AVGAS more frequent oil changes will be required !
(see also ROTAX® Service Information SI-18-1997 latest revision, for more information.)

Max. Oil Capacity : 3,0 (Liters)
 Quantity between Max/Min 0,45 (Liters)
 Max. Oil Consumption: 0,06 (Liters/h)

Document No.:	Issue:	Revised Issue:	Date:	Page:
FM-AT01-1010-100E	A.08	A.01	30.6.05	1-7

1.9.2 Engine Coolant

The following waterfree coolant concentrate based on propylene glycol is the only to be used for Aquila AT01.

Designation	Mixture Ratio %	
	Concentrate	Water
EVANS NPG+®	100	0

When correctly applied (100% coolant concentration), there is sufficient protection against vapour bubble formation, freezing or thickening of the coolant within the operating limits.

WARNING

The coolant concentrate EVANS NPG+® may not be mixed with convetional glycol/water coolant or with additives. Non-observance can lead to damages to the cooling system and to motor damages, since the properties of the coolant no longer exist. (see also ROTAX® SB-912-043, latest revision for more information.)

CAUTION

Qualitatively inferior and contaminated coolant can lead to deposits in the cooling system, which may result in a bad, insufficient engine cooling.

Coolant Quantity Total: Minimum: 2,4 (Liters)
Maximum: 2,5 (Liters)

Coolant Quantity in the Overflow Bottle: Minimum: 0,1 (Liters)
Maximum: 0,2 (Liters)

1.10 WEIGHTS

Max. Takeoff Weight (MTOW): 750 (Kg)
 Max. Landing Weight (MLW): 750 (Kg)
 Empty Weight (MZFV): Refer to section 6
 Max. Weight in Baggage Compartment: 40 (Kg)
 Max. Wing Loading: 71,4 (Kg/m²)
 Min. Wing Loading: ca. 52,6 (Kg/m²)

Document No.:	Issue:	Revised Issue:	Date:	Page:
FM-AT01-1010-100E	A.08	A.01	30.6.05	1-8

1.11 TERMINOLOGY AND ABBREVIATIONS

1.11.1 Airspeeds

IAS: (Indicated Airspeed), Speed as shown on the airspeed indicator.

KIAS: IAS expressed in Knots

CAS: (Calibrated Airspeed), Means the indicated airspeed, corrected for position and instrument error. CAS is equal to true airspeed in standard atmosphere at sea level.

KCAS: CAS expressed in Knots

TAS: (True Airspeed), Airspeed relative to undisturbed air, which is the CAS corrected for altitude, temperature and compressibility.

GS: (Ground speed), Airspeed relative to ground.

V_A: Maneuvering Speed

V_S: Stalling speed without engine power.

V_{SO}: Stalling speed without engine power in the landing configuration.

V_X: Best Angle-of-Climb Speed

V_Y: Best Rate-of-Climb Speed

V_{FE}: Maximum Flap Extended Speed

V_{NE}: Never Exceed Speed - The speed limit that should not be exceeded at any time.

V_{NO}: Maximum Structural Cruising Speed is the speed that should not be exceeded except in smooth air and then only with caution.

1.11.2 Weight and Balance

Reference Datum An imaginary vertical plane from which all horizontal distances are measured for balance purposes.
Reference line fixed horizontal reference line

Document No.:	Issue:	Revised Issue:	Date:	Page:
FM-AT01-1010-100E	A.08	A.01	30.6.05	1-9

Arm: The horizontal distance from the reference datum to the center of gravity (C.G.) of an item.

Moment: The product of the weight of an item multiplied by its arm.

Empty Weight: Weight of the aircraft including unusable fuel, full operating liquids and full oil.

Max. Takeoff Weight: Maximum weight approved for the start of the takeoff run.

Useful Load: Difference between takeoff weight and basic empty weight.

Usable Fuel : Fuel available for flight planning.

Unusable Fuel: Fuel remaining in the fuel tanks that cannot be safely used in flight.

Center of Gravity: The point at which an aircraft would balance if suspended.
C.G.

MAC: Mean aerodynamic chord

1.11.3 Meteorological Terminology

OAT: Outside Air Temperature

VFR, day day: (SR) Sunrise-30 min to (SS) Sunset+30 min

1.11.4 Engine and Performance

Takeoff Power: Maximum power permissible for takeoff.

Max. Continuous Power: Maximum power permissible continuously during flight.

1.11.5 Miscellaneous

Serial No.: Serial Number of the Aircraft

Part No.: Part Number

GFRP: Glass Fiber Reinforced Plastic

CFRP: Carbon Fiber Reinforced Plastic

ACL: Anti Collision Light

<i>Document No.:</i>	<i>Issue:</i>	<i>Revised Issue:</i>	<i>Date:</i>	<i>Page:</i>
FM-AT01-1010-100E	A.08	A.01	30.6.05	1-10

1.12 CONVERSION FACTORS

1.12.1 Length

$$1 \text{ (ft)} = 0,304 \text{ (m)}$$

$$1 \text{ (in)} = 25,4 \text{ (mm)}$$

1.12.2 Airspeed

$$1 \text{ (kts)} = 1,852 \text{ (Km/h)}$$

$$1 \text{ (mph)} = 1,609 \text{ (Km/h)}$$

1.12.3 Pressure

$$1 \text{ (hPa)} = 100 \text{ (N/m}^2\text{)} = 1 \text{ (mbar)}$$

$$1 \text{ (in. Hg)} = 33,865 \text{ (hPa)}$$

$$1 \text{ (psi)} = 68,97 \text{ (mbar)}$$

1.12.4 Mass ("Weight")

$$1 \text{ (lbs)} = 0,454 \text{ (Kg)}$$

1.12.5 Volume

$$1 \text{ (US Gallon)} = 3,78 \text{ (Liter)}$$

$$1 \text{ (Imperial Gallon)} = 4,546 \text{ (Liter)}$$

1.12.6 Temperature

$$(t)^\circ\text{C (Celsius)} = 5/9((t)^\circ\text{F}-32)$$

$$(t)^\circ\text{F (Fahrenheit)} = 9/5(t)^\circ\text{C}+32$$

$$=$$

Document No.:	Issue:	Revised Issue:	Date:	Page:
FM-AT01-1010-100E	A.08	A.01	30.6.05	1-11

1.12.7 RESERVED

Intentionally left blank

<i>Document No.:</i>	<i>Issue:</i>	<i>Revised Issue:</i>	<i>Date:</i>	<i>Page:</i>
FM-AT01-1010-100E	A.08	A.01	30.6.05	1-12